

INSTRUCTION MANUAL

C-SERIES CYLINDRICAL TYPE PHOTOELECTRIC SENSOR

- Thank you for purchasing C-series cylindrical type photoelectric sensor. Check that the specifications agree with yours.
- Please read this manual through before using the sensor, and retain it for future reference.

SPECIFICATIONS

Item	DC type				
	Through beam type	Retro-reflection type		Diffused reflection type	
				With polarizing filter	
	CTD-1500(C) (N, P)	CRD-300(C) (N, P)	CRDF-100(C) (N, P)	CDD-11(C) (N, P)	CDD-40(C) (N, P)
Detecting distance	15m	0.05~3m	0.05~1m	※ 11cm	※ 40cm
Supply voltage	DC 10~30V				
Current consumption	40mA max.	30mA max.			
Detecting object	Opaque object □ 15mm min.	Opaque object □ 45mm min.		Transparent and opaque object.	
Response time	1.5ms max.				
Hysteresis				15% max. (at 11cm)	20% max. (at 40cm)
Light source	IR LED		Red LED	IR LED	
Sensitivity adjustment	I rotation volume			I rotation volume	
Indicator	Incident indicator (Red)		Power indicator for Emitter		
Control output	NPN or PNP open collector		100 mA max. DC 30V		
Operation mode	LIGHT ON, DARK ON selectable by control cable				
Connection	Cable : PVC φ 5×2 m, 4×0.3 mm ² Connector : M12×4 pins				
Noise resistance	1000 Vp, pulse width 1 μs (Noise simulator)				
Insulation resistor	20 MΩ min. (at DC 500 V)				
Ambient temperature humidity	-25~55°C (There should be no freezing)/35~85 % RH				
Environmental illuminance	Sunlight : 10000 lx max. Incandescent lamp : 3000 lx max.				
Vibration Shock resistance	Vibration: 10~55 Hz, amplitude 1.5 mm, X, Y, Z ea. 2 Hrs., Shock: 500 m/s ² (50 G) X, Y, Z ea. 3 times				
Protection category material	IP 66 (IEC 144), Case: BSBM, Lens: PC (PMMA for polarizing filter type)				

※ □ 20cm white paper

INPUT AND OUTPUT CIRCUIT DIAGRAMS

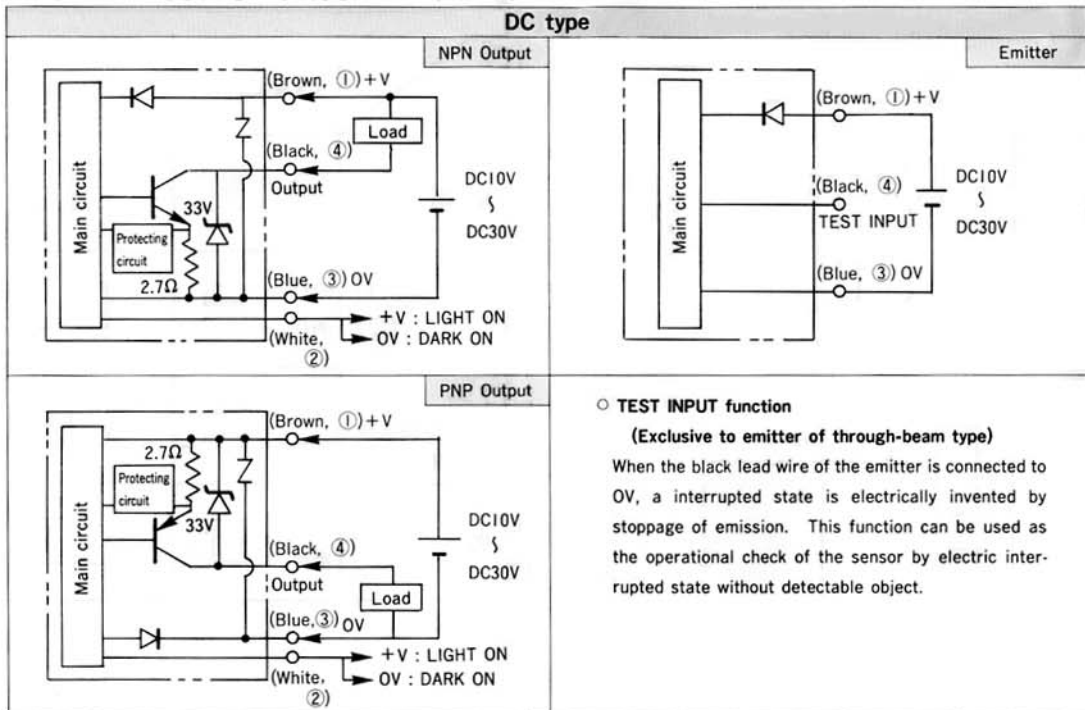

HOW TO USE

● Connection diagram

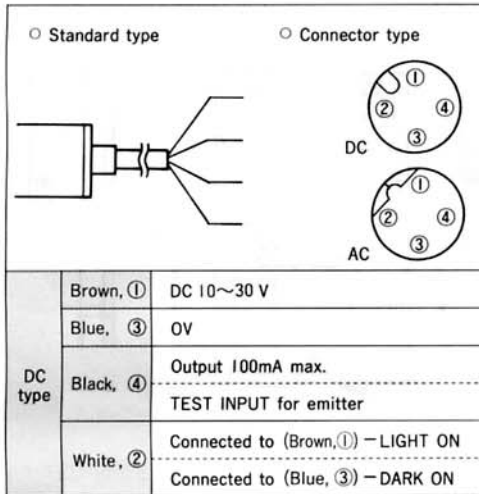

● Other precautions

- Be careful not to install the sensor at the following locations, for it may otherwise malfunction :
 - Where a lot of dust, vapor, or the like is present
 - Where corrosive gases are produced
 - Where water, oil or the like flies directly onto the sensor.
 - Where strong vibration or shock is caused to the sensor.
- Do not use organic solvent, such as thinner, to remove contaminants from the lens, which are all of plastics. Using a dry rag, just wipe clean.
- When a switching regulator is to be used with a power supply, be sure to ground the frame ground (F. G.) terminal.
- Do not use the sensor in a transient state at a turn-on (DC type : about 40 ms, AC type : about 200 ms).

● Adjusting the optical axis.

○ Through-beam type

1. Install the emitter and the receiver opposite to each other so that the optical axis lines up.
2. Move the emitter and the receiver vertically and from side to side, and fix each at the mid-point in the range where the indicating lamp at the receiver lights up.

○ Reflection type

Move the sensor vertically and from side to side, and fix it at the mid-point in the range where the indicating lamp lights up.

● Adjusting the sensitivity control

1. Set the detectable object at the detection position and turn the sensitivity control slowly from MIN toward MAX until the indicating lamp lights up. Call it position A.
2. Remove detectable object and turn the sensitivity control from MAX toward MIN position where the indicating lamp is extinguished. Call it position B.
3. Point C midway between A and B is the optimum sensitivity position.

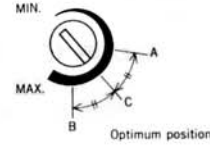

● Accessories

○ Reflection mirror (for Retro-reflection type)

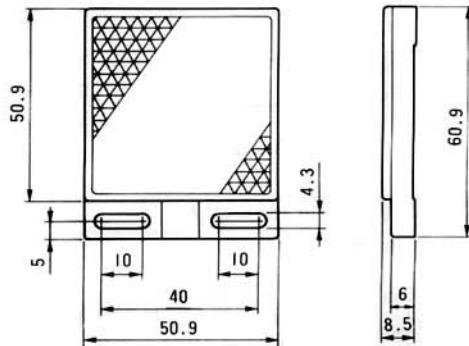

(Unit : mm)

DIMENSIONS

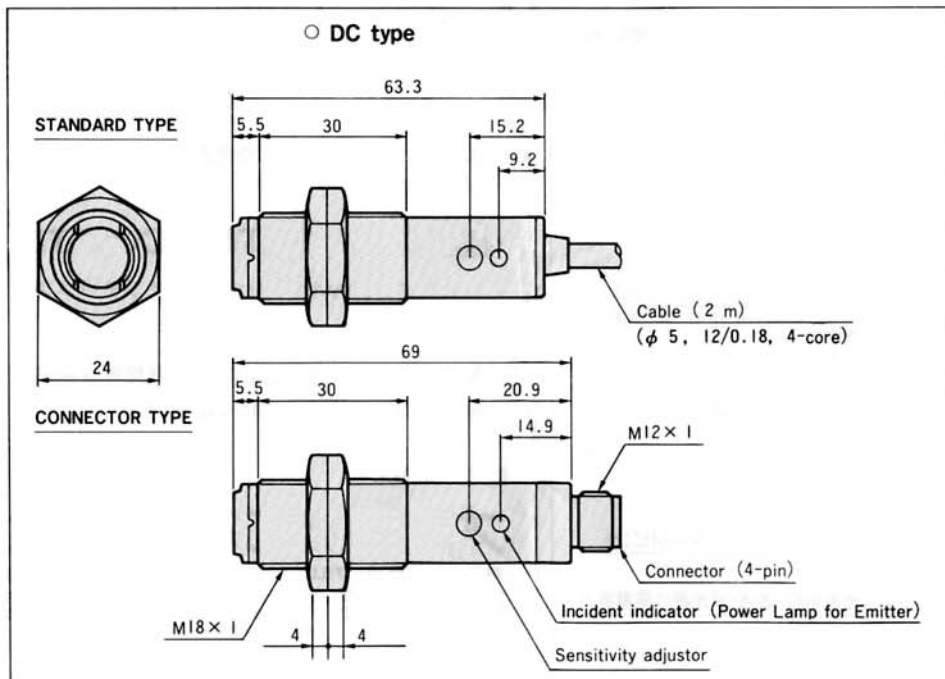

● OPTEX CO., LTD.

- Product specifications are subject to change for improvement without notice.

OPTEX CO., LTD.
4-7-5 Nionohama Otsu 520-0801 JAPAN
TEL:0777524-1900 FAX:0777524-3201 TELEX:5464852 OPTEX J

2001.07.0530236

Optex-FA U.S. Sales
Ramco Innovations
(800) 280-6933
www.optex-ramco.com