



Photoelectric Sensor

BGS-V2000 SERIES

AC/DC Type
DC Type

AC/DC Type

BGS-V2000 BGS-V2000T

DC Type

BGS-V2000

INSTRUCTION MANUAL

- i Confirm if the item meets your needs.
- i Before the use, you should first thoroughly read this manual and operate correctly as mentioned.
- i You should keep this manual at hand for proper use.

SPECIFICATIONS

Cable type Connector type	AC/DC type	DC type
	BGS-V2000(T)	BGS-V2000(N,P) BGS-V2000(CN,CP)
Detection distance	0.5 ~ 2m (*1)	
Detecting object	Opaque object	
Supply voltage	12 ~ 24 VDC +/- 10% 24 ~ 240 VAC +/- 10% 50/60 Hz.	10 ~ 30 VDC +/- 10%
Current consumption	5VA max.	50mA max.
Response time	20ms max.	5ms max.
Hysteresis	15% max. (@ 1m)	5% max. (@ 2m)
Light Source	IR LED	
Sensitivity adjustment	Teaching button	
Timer function	ON/OFF Delay 1 ~ 10 sec.	-----
Indicator	Output indicator: Orange LED, Stable incident indicator: Green LED	
Control output	Relay output 1c 240 VAC 3A max. 30 VDC 3A max.	NPN/PNP Open collector 30 VDC 100 mA max.
Operation mode	Light ON	Light ON / Dark ON Select by switch
Connection	Terminal base	Terminal base / M12 connector
Insulation Resistor	20 M ohm min. (500 VDC)	
Withstand Voltage	2700 VAC 1 minute	-----
Ambient temp./humidity	-25 ~ 55° C / 35 ~ 95% RH	
Ambient light	Ambient light Sunlight F10,000lx max.	Incandescent lamp 3,000 lx max.
Protection category/Material	IP67 / Case: ABS, Lens: PC	
Weight	110g	95g

*1 0.5m x 0.5m white paper

INPUT AND OUTPUT DIAGRAMS

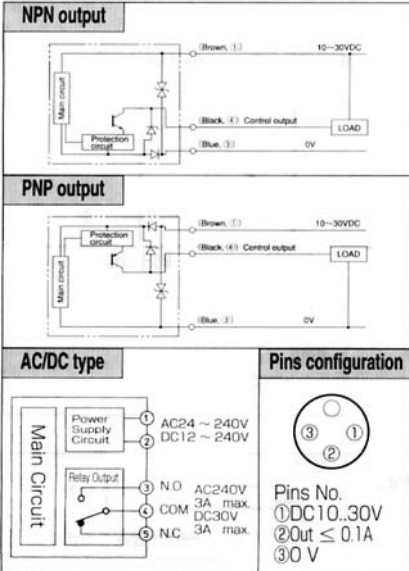

PART IDENTIFICATION

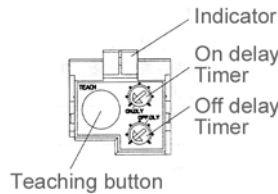
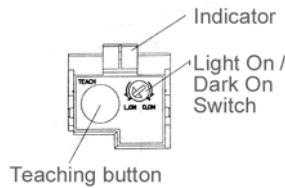

HOW TO USE

● Connection

- Install the cables to match the connection terminal No. as shown below.
- Use either lead-in opening A or B according to the installation method involved.
- Install a vinding bolt at the lead-in opening not to be used.
 - The figure below shows how the cables are installed when lead-in opening A is used.
 - ※1 Cable packing is selected separately either for cable or blinding bolt according to cable diameter.
 - Large : φ 8 ~ φ 10 Small : φ 6 ~ φ 8
 - ※2 Washer is to be used exclusively to the cable bolt.

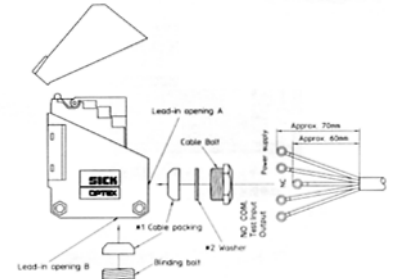

- Dimensions of applicable solderless terminals

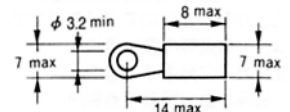

- Use solderless terminals with insulating tube.
- Use 6 to 10 mm diameter cables circular in section to maintain watertightness.
- Wrong wiring may be a cause of burned or damaged sensor. Pay due attention to wiring.
- Be careful not to install the cable near power lines, for otherwise the sensor may malfunction.
- Using the mounting accessories supplied, the sensor can be installed on either floor or wall.

TEACHING PROCEDURE (SENSITIVITY ADJUSTMENT)

1) Depending upon the duration that the TEACHING BUTTON is pressed, the teaching mode can be changed.

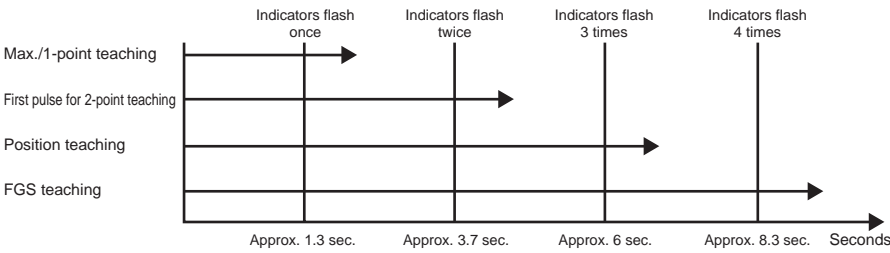

Sensitivity is set at Max. in default state.

MAX. TEACHING (Max. sensitivity adjustment)

1. Press the button without any objects / background present.
2. Release the button after the indicators flash simultaneously 1 time.
3. Teaching is complete.

Switching point



ONE-POINT TEACHING

1. Press the button on the background (Without a target present).
2. Release the button after the indicators flash simultaneously 1 time.
3. Teaching is complete.

Switching point



switching point is adjusted in the front of background.

TWO-POINT TEACHING

- First point**
1. Press the button until the indicators flash simultaneously, 2 times. After blinking 2 times, release the button. The first point is stored, and then the sensor turns to the input state for the second point starting simultaneous blinking of the indicators.
- Second point**
2. Press the button (Any duration). The indicators flash simultaneous 2 times - Complete. The indicators flash alternately 3 times - Teaching error. Restart from the first step.

Switching point

Switching point is adjusted at the middle between the first and second point.

POSITION TEACHING

1. Place the object at a location from the sensor where the output should be ON, and press the button.
2. Release the button after the indicators flash simultaneously 3 times.
3. Teaching is complete (No OK sign appears). The indicators will flash alternately 3 times if there is a Teaching error. Restart from the first step.

Switching point

Teaching position of the object is switching point.

FGS TEACHING (FGS is a function that detecting range can be adjusted as desired, out of the range is suppressed.)

1. Press the button on the background (Without a target present).
2. Release the button after the indicators flash simultaneously 4 times.
3. Teaching is complete.

If the indicators flash alternately 3 times a Teaching error has occurred. Restart from the first step.

Switching point

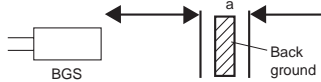

Light ON ON point in the limit of "a".
Dark ON OFF point in the limit of "a".

Note:

1. Releasing the button the indicators will flash simultaneously 1 time, the switching point is not stored (Excluding the second point in two point teaching).
2. In case of a teaching error, the sensor is automatically reset and returns to the function from the previous state.

DIMENSIONS

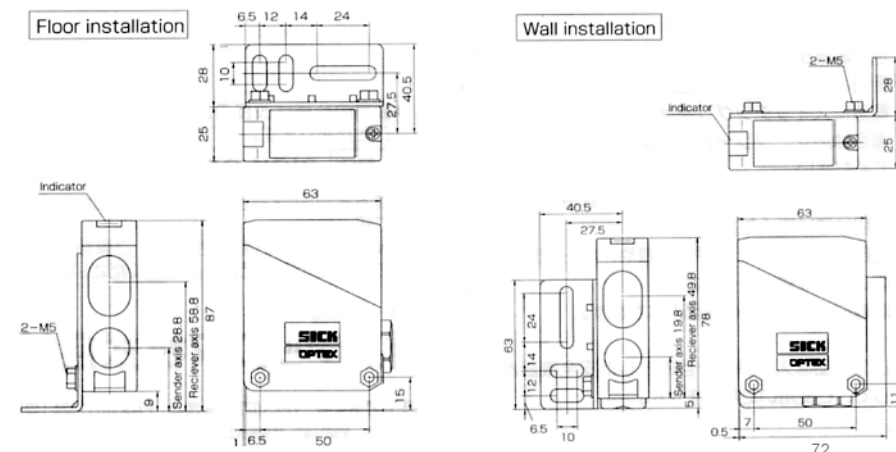

TIMER CHART

Timer period (0.1 ~ 10S)

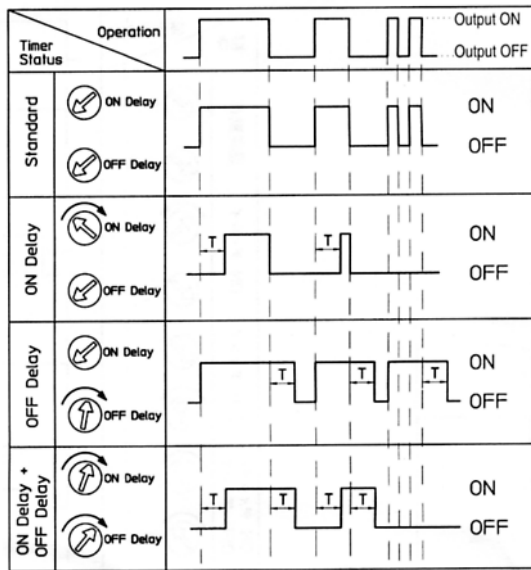

PRECAUTIONS

- Be careful not to install the sensor at the following locations, as it may otherwise malfunction.
- Where a lot of dust, vapor, or the like is present.
 - Where corrosive gas is produced.
 - Where water, oil or the like flies directly onto the sensor.
 - Where strong vibration or shock is caused to the sensor.

Do not use organic solvent, such as thinner, to remove contaminants from the body case, lid, and lens which are all of plastics. Using a dry rag, just wipe clean.

When a switching regulator is to be used with a power supply, be such to ground the Frame Ground Terminal.

Do not use the sensor in a transient state at power on.(about 100ms)

Do not run sensor cable near a high-voltage lines, or power lines or put them together in the same raceway. This warning should be strictly observed to prevent malfunctions caused by inductive interference.

⚠ Must not use this item as safety equipment for the purpose of human body protection.

- Specifications and equipment are subject to change without any obligations on the part of manufacture.
- For more information, questions and comments regarding products, please contact us below.

Developed by :

OPTEX CO.,LTD.

Manufactured and sold by :

OPTEX FA OPTEX FA CO.,LTD.

607-8085 Kyoto, Yamashina, Takehanadonomaecho 46-1, JAPAN

Website : <http://www.optex-fa.com>

Optex-FA U.S. Sales
Ramco Innovations
(800) 280-6933

www.optex-ramco.com