

NA40 SERIES

40 mm Beam Pitch General Purpose Area Sensor



Slim and intelligent

Refer to p.419~ for the light curtain.

Slim body

The **NA40** saves space as the volume is reduced to 1/3 of a conventional model.

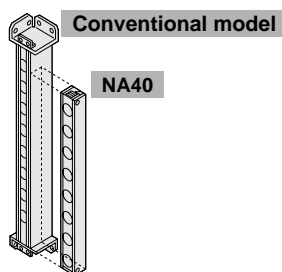

Failure monitoring

When one of the following errors occurs, the self-diagnosis output is generated and three color indicators reveal the failure condition.

- ① **Reduction of incident light intensity**
The **NA40** monitors the incident light intensity for reduction due to dust or dirt on the front faces, or beam misalignment.

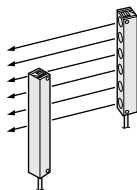

Close mounting

Two sets of sensors can be closely mounted by setting different emission frequencies to prevent mutual interference.

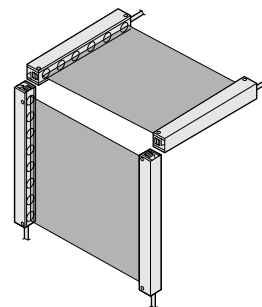

Easy modification of length

The modular construction enables modification of the number of beam channels. It makes a design change or maintenance on the site very simple.

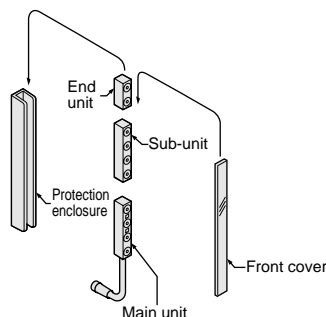

- ② **Failure of the output transistor**
Any failure of the output transistor is monitored.

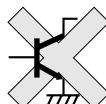

Robust aluminum enclosure

The modules are protected by a robust aluminum enclosure conforming to IP65 protection.

APPLICATIONS

Detecting intrusion into loader or unloader

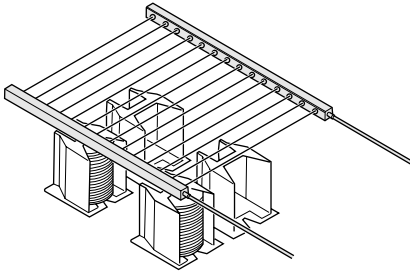

Verifying picking of parts from shelf

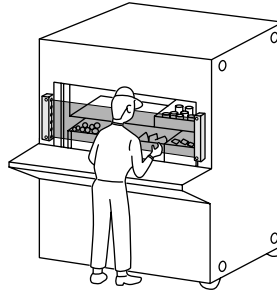

Controlling access on tape feeder

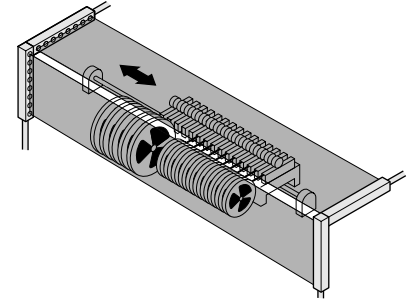

WARNING Never use this product in any personnel safety application.

ORDER GUIDE

Sensors Mating cable is not supplied with the sensor. Please order it separately.

Type	Appearance	Sensing range	Model No.	Number of beam channels	Sensing height (mm)	Output
Area sensor		5 m	NA40-4	4	120	NPN open-collector transistor
			NA40-6	6	200	
			NA40-8	8	280	
			NA40-10	10	360	
			NA40-12	12	440	
			NA40-14	14	520	
			NA40-16	16	600	
			NA40-20	20	760	
			NA40-24	24	920	
			With spatter protection hood		NA40-4-H	
	NA40-6-H	6			200	
	NA40-8-H	8			280	
	NA40-10-H	10			360	
	NA40-12-H	12			440	
	NA40-14-H	14			520	
	NA40-16-H	16			600	
	NA40-20-H	20			760	
	NA40-24-H	24			920	

Mating cables Mating cable is not supplied with the sensor. Please order it separately.

Appearance	Model No.	Description
	NA40-CC3	Length: 3 m Weight: 600 g approx. (two cables) 0.5 mm ² 3-core (receiver: 4-core) cabtyre cable with connector on one end, two cables per set. Cable outer diameter: ϕ 6.7 mm
	NA40-CC7	Length: 7 m Weight: 950 g approx. (two cables) Connector outer diameter: ϕ 14 mm max. Cable color: Gray (for emitter) Black (for receiver)

NA40

ORDER GUIDE

Accessory

- MS-NA40-1 (Sensor mounting bracket)

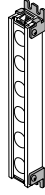

Four bracket set
 Four M5 (length 40 mm) truss head screws, four nuts and four spring washer are attached.

Individual units and associated components can be purchased separately.

Designation	Number of beam channels	Model No.	
		Emitter	Receiver
Main unit	4	NA40-MUP	NA40-MUD
Sub-unit	4	NA40-4SUP	NA40-4SUD
End unit	2	NA40-2EUP	NA40-2EUD
	4	NA40-4EUP	NA40-4EUD
End cap (Note)	—	NA40-ECP	NA40-ECD

Note: It is required only for NA40-4 or NA40-4-H.

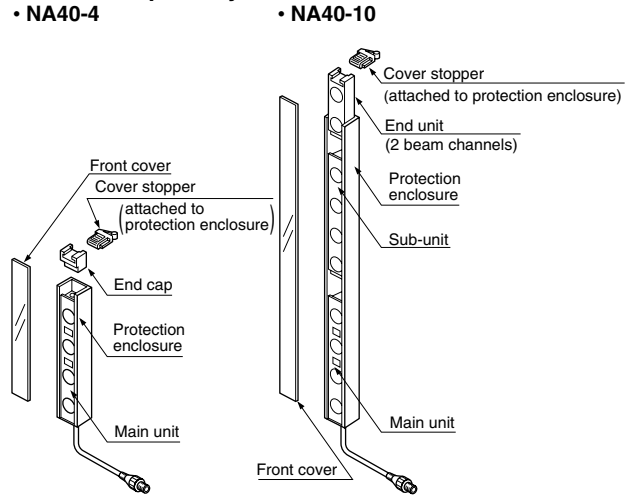

Designation		Applicable beam channels	4 beam channels	6 beam channels	8 beam channels	10 beam channels	12 beam channels	14 beam channels	16 beam channels	20 beam channels	24 beam channels
		Model No.	MC-NA40-4	MC-NA40-6	MC-NA40-8	MC-NA40-10	MC-NA40-12	MC-NA40-14	MC-NA40-16	MC-NA40-20	MC-NA40-24
Protection enclosure	Model No.										
	With spatter protection hood	Model No.	MC-NA40-4H	MC-NA40-6H	MC-NA40-8H	MC-NA40-10H	MC-NA40-12H	MC-NA40-14H	MC-NA40-16H	MC-NA40-20H	MC-NA40-24H
Front cover	Model No.	FC-NA40-4	FC-NA40-6	FC-NA40-8	FC-NA40-10	FC-NA40-12	FC-NA40-14	FC-NA40-16	FC-NA40-20	FC-NA40-24	

Note: The model Nos. given above denote a single unit, not a pair of units.

OPTIONS

Designation		Applicable beam channels	4 beam channels	6 beam channels	8 beam channels	10 beam channels	12 beam channels	14 beam channels	16 beam channels	20 beam channels	24 beam channels
		Model No.	OS-NA40-4	OS-NA40-6	OS-NA40-8	OS-NA40-10	OS-NA40-12	OS-NA40-14	OS-NA40-16	OS-NA40-20	OS-NA40-24
Slit mask	Model No.										

Note: The model Nos. given above denote a single unit, not a pair of units.

Designation	Model No.	Description
Large indicator for area sensor	SF-IND	With the large indicators put on the sensors, the operation is easily observable from various directions. (Refer to p.1106 for details)

Note: Two SF-INDs are required if they are to be mounted on, both, the emitter and the receiver.

Slit mask

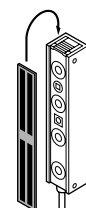

The slit mask restrains the amount of beam emitted or received and hence reduces the interference between neighboring sensors. It is also used in cases when the beam intensity is too strong penetrating through the sensing object. Replace the original front cover with the slit mask. However, the sensing range reduces when the slit mask is used.

Sensing range

- Slit on emitter side: 1.3 m
- Slit on receiver side: 3 m
- Slit on both sides: 0.8 m

Large indicator for area sensor

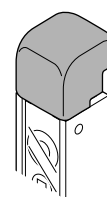

The large indicator can be easily mounted on the sensor head at the top. It also can be mounted on an area sensor already being used.

SPECIFICATIONS

Number of beam channels		4	6	8	10	12	14	16	20	24
Item	Model No.	NA40-4	NA40-6	NA40-8	NA40-10	NA40-12	NA40-14	NA40-16	NA40-20	NA40-24
	With spatter protection hood	NA40-4-H	NA40-6-H	NA40-8-H	NA40-10-H	NA40-12-H	NA40-14-H	NA40-16-H	NA40-20-H	NA40-24-H
Sensing height		120 mm	200 mm	280 mm	360 mm	440 mm	520 mm	600 mm	760 mm	920 mm
Sensing range		5 m								
Beam pitch		40 mm								
Sensing object		φ60 mm or more opaque object								
Supply voltage		12 to 24 V DC ± 10 % Ripple P-P 10 % or less								
Current consumption		Emitter: 30 mA or less Receiver: 60 mA or less			Emitter: 35 mA or less, Receiver: 90 mA or less				Emitter: 35 mA or less Receiver: 115 mA or less	
Sensing output		NPN open-collector transistor <ul style="list-style-type: none"> • Maximum sink current: 100 mA • Applied voltage: 30 V DC or less (between sensing output and 0 V) • Residual voltage: 1.6 V or less (at 100 mA sink current) 								
Output operation		ON when all beam channels are received / OFF when one or more beam channels are interrupted								
Short-circuit protection		Incorporated								
Self-diagnosis output		NPN open-collector transistor <ul style="list-style-type: none"> • Maximum sink current: 50 mA • Applied voltage: 30 V DC or less (between self-diagnosis output and 0 V) • Residual voltage: 1.6 V or less (at 50 mA sink current) 								
Output operation		OFF when unstable light received condition continues for 5 sec. or more, or the output transistor fails								
Short-circuit protection		Incorporated								
Response time		12 ms or less								
Indicator		Incorporated with the three color indicators on the receiver <ul style="list-style-type: none"> • Sensing output operation indicator: Red LED (lights up when one or more beam channels are interrupted) • Stable incident beam indicator: Green LED (lights up when all beam channels are received stably) • Unstable incident beam indicator: Yellow LED (lights up when one or more beam channels are received unstably) ※When the output transistor fails, the three color indicators blink simultaneously.								
Interference prevention function		Incorporated (Two units of sensors can be mounted close together.)								
Environmental resistance	Protection	IP65 (IEC)								
	Ambient temperature	- 10 to + 50 °C (No dew condensation or icing allowed), Storage: - 10 to + 60 °C								
	Ambient humidity	35 to 85 % RH, Storage: 35 to 85 % RH								
	Ambient illuminance	Sunlight: 11,000 lx at the light-receiving face, Incandescent light: 3,500 lx at the light-receiving face								
	Noise immunity	Power line: 240 Vp and 0.5 μs pulse width (with noise simulator)								
	Voltage withstandability	1,000 V AC for one min. between all supply terminals connected together and enclosure								
	Insulation resistance	20 MΩ, or more, with 500 V DC megger between all supply terminals connected together and enclosure								
	Vibration resistance	10 to 55 Hz frequency, 1.5 mm amplitude in X, Y and Z directions for two hours each								
Shock resistance	100 m/s ² acceleration (10 G approx.) in X, Y and Z directions for three times each									
Emitting element		Infrared LED (synchronized scanning system)								
Material		Protection enclosure: Aluminum, Unit case: ABS, Front cover: Acrylic, Lens: Acrylic								
Cable		0.5 mm ² 4-core (emitter: 3-core) cabtyre cable, 0.5 m long, with a round connector at the end ※Use together with the optional mating cable								
Cable extension		Extension up to total 100 m is possible, for both emitter and receiver, with 0.5 mm ² , or more, cable. (However, the interference prevention wire can extend up to 20 m between two emitters.)								
Weight (Total of emitter and receiver)		400 g approx.	500 g approx.	630 g approx.	770 g approx.	890 g approx.	1,020 g approx.	1,150 g approx.	1,400 g approx.	1,660 g approx.
With spatter protection hood		500 g approx.	630 g approx.	800 g approx.	990 g approx.	1,150 g approx.	1,330 g approx.	1,500 g approx.	1,840 g approx.	2,190 g approx.
Accessories		MS-NA40-1 (Sensor mounting bracket): 1 set for emitter and receiver, Adjusting screwdriver: 1 pc.								

NA40

I/O CIRCUIT AND WIRING DIAGRAMS

I/O circuit diagrams

Emitter

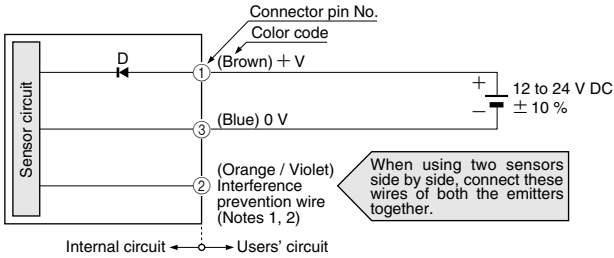

Receiver

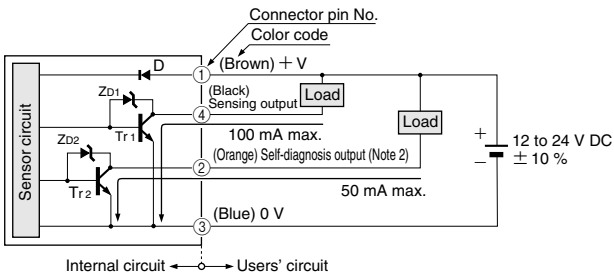

Symbols ... D: Reverse supply polarity protection diode
 Z_{D1}, Z_{D2}: Surge absorption zener diode
 Tr₁, Tr₂: NPN output transistor

- Notes: 1) If the interference prevention wires (orange / violet) are not used, please insulate them.
 2) Never connect the emitter's interference prevention wire (orange / violet) to the receiver's self-diagnosis output (orange). This can cause damage.

Wiring diagrams

Emitter

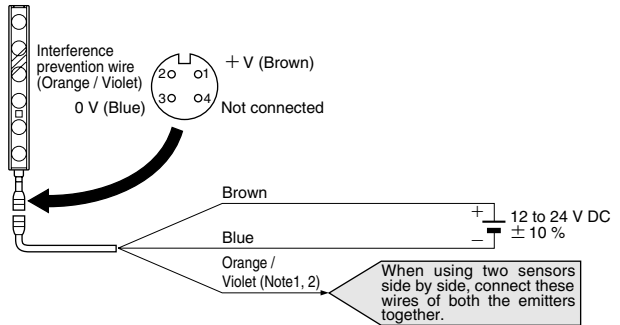

Receiver

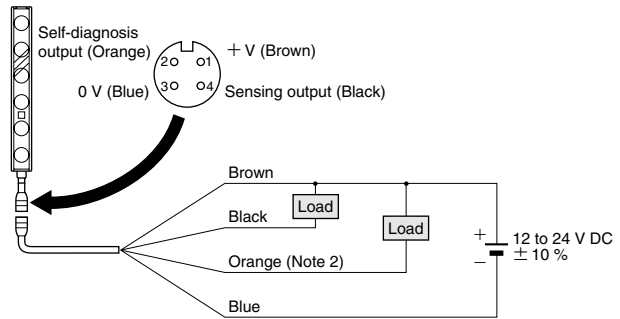

- Notes: 1) If the interference prevention wires (orange / violet) are not used, please insulate them.
 2) Never connect the emitter's interference prevention wire (orange / violet) to the receiver's self-diagnosis output (orange). This can cause damage.

SENSING CHARACTERISTICS (TYPICAL)

Parallel deviation (All models)

Vertical direction

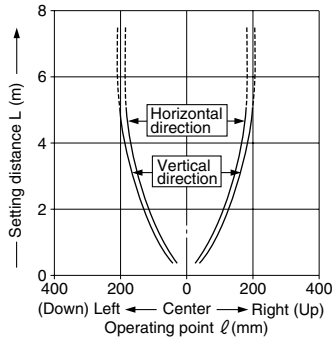
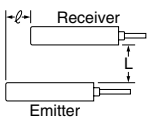

Horizontal direction

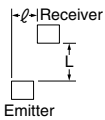

Angular deviation (All models)

Emitter angular deviation

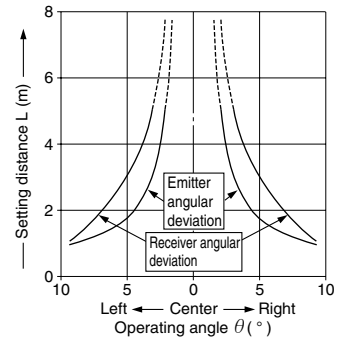
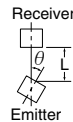

Receiver angular deviation

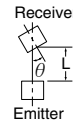

PRECAUTIONS FOR PROPER USE

Refer to p.1135~ for general precautions.



- Never use this product as a sensing device for personnel protection.
- For sensing devices to be used as safety devices for press machines or for personnel protection, use products which meet standards, such as OSHA, ANSI or IEC etc., for personnel protection applicable in each region or country.
- If this product is used as a sensing device for personnel protection, death or serious body injury could result.
- For a product which meets safety standards, use the following products.
Type4 : **SF4-AH** series (p.420~), **SF2-EH** series (p.486~)
Type2 : **SF2-A** series (p.446~), **SF2-N** series (p.464~)

Mounting

- Do not use the sensor without the front cover or the enclosure. IP protection cannot be maintained and a contact failure may occur between the modular units.
- When mounting the sensor, the tightening torque should be 1.96 N·m or less.

Setting of frequency selection switch

- Turn the frequency selection switches with the enclosed screwdriver and select the appropriate frequencies (in power supply off condition).

When using one set of sensor

Setting of frequency selection switches

Emitter	Receiver

Set the switches of both the emitter and the receiver at '1'. The sensor does not function normally at other settings.

When using two sets of sensors

When two sets of sensors are closely mounted as shown in the illustration on the right, set the switches as follows.

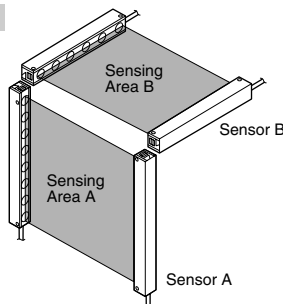

- 1 Select the frequencies.

	Setting of frequency selection switches	
	Emitter	Receiver
Sensor A		
Sensor B		

Set the switches of both the emitter and the receiver of Sensor A at '1', and both switches of Sensor B at '2'. The sensors do not function normally at other settings.

- 2 Connect the interference prevention wires (INTER LOCK) of Sensor A and Sensor B together.

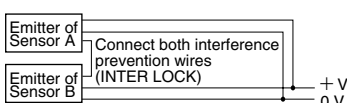

- Connect both the 0V wires in common.
- +V wires need not be connected in common.

Note: The overall wiring distance between Sensor A and Sensor B must be within 20 m. The interference prevention wire length and the 0 V wire length between the emitters must be within 20 m each, too.

Other

- Do not use during the initial transient time (0.5 sec.) after the power supply is switched on.

Operation of indicator

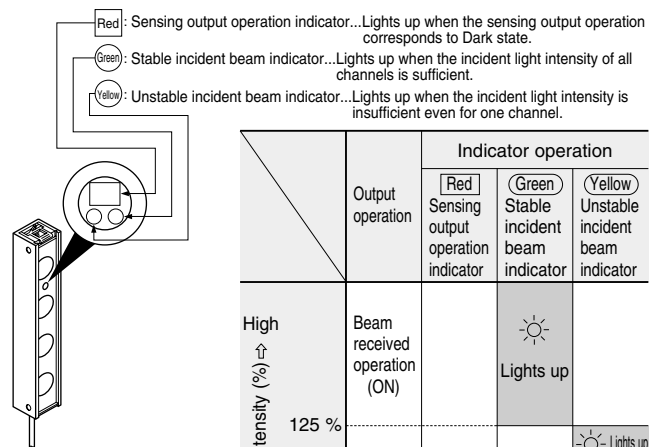

	Output operation	Indicator operation		
		Red Sensing output operation indicator	Green Stable incident beam indicator	Yellow Unstable incident beam indicator
High Incident light intensity (%) ⇕ 125 %	Beam received operation (ON)		Lights up	
	Beam interrupted operation (OFF)	Lights up		Lights up
100 %				Lights up
Low Incident light intensity (%) ⇕ 0 %				

Note: If the sensing output transistor fails, the three color indicators blink.

How to change the number of beam channels

- 1 Slide the cover stopper in the direction of the arrow and pull the front cover upward.
- 2 Remove the four fixing screws on the rear face. Pull the modules upward one by one with your hands.

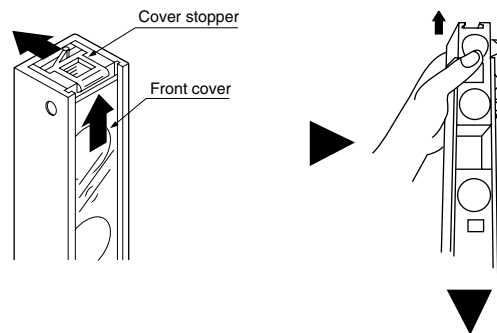

- 3 Prepare the new protection enclosure and front cover that matches the required sensing height. Insert the units and connect the end cap.
- 4 Tighten the four fixing screws and insert the front cover by pulling the cover stopper back.

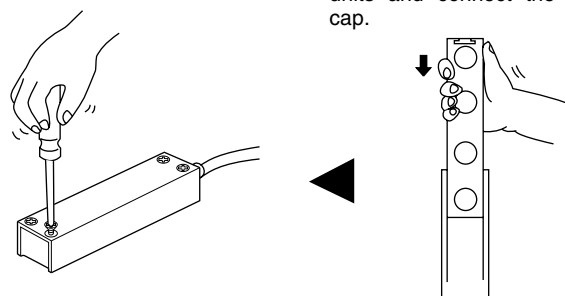

- Notes:
- 1) Be sure to turn the power off before linking units. If this is not done, the sensor may get damaged.
 - 2) The end unit, either 2-channel unit or 4-channel unit, must be connected at the top of the module linkage.
 - 3) Be sure to put the end cap on the top of the 4 beam channel **NA40-4** or **NA40-4-H**.
 - 4) The cover stopper and four fixing screws are attached with the protection enclosure.

DIMENSIONS (Unit: mm in) The CAD data in the dimensions can be downloaded from the SUNX website: <http://www.sunx.co.jp/>

MS-NA40-1 Sensor mounting bracket (Accessory)

Assembly dimensions

Mounting drawing with NA40-□.

The assembly for the spatter protection hood type (NA40-□-H) is similar.

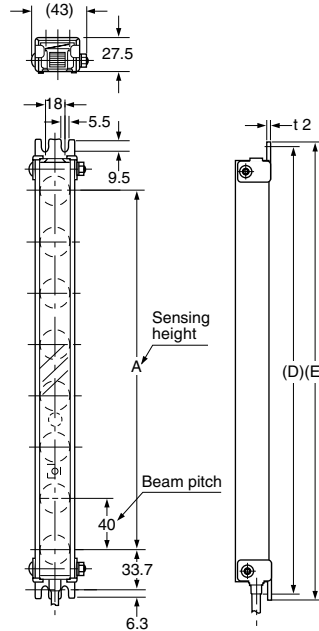
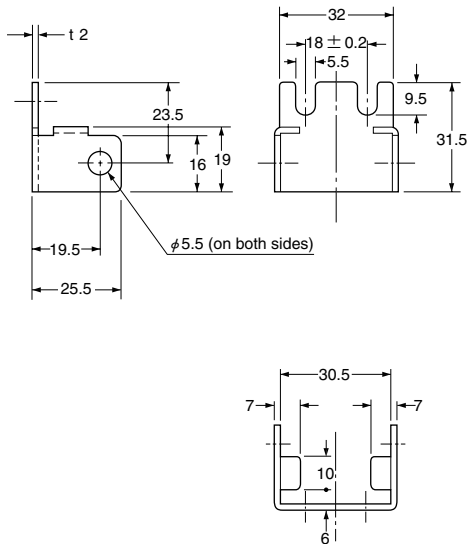

Model No.	A	D	E
NA40-4(-H)	120	200	210
NA40-6(-H)	200	270	280
NA40-8(-H)	280	350	360
NA40-10(-H)	360	430	440
NA40-12(-H)	440	510	520
NA40-14(-H)	520	590	600
NA40-16(-H)	600	670	680
NA40-20(-H)	760	830	840
NA40-24(-H)	920	990	1,000

Material: Cold rolled carbon steel (SPCC)
(Uni-chrome plated)

Four bracket set
(4 pcs. each of M5 (length 40 mm) truss head screws, nuts and spring washers are attached.)

SF-IND Large indicator for area sensor (Optional)

Assembly dimensions

Mounting drawing with NA40-□.

The assembly for the spatter protection hood type (NA40-□-H) is similar.

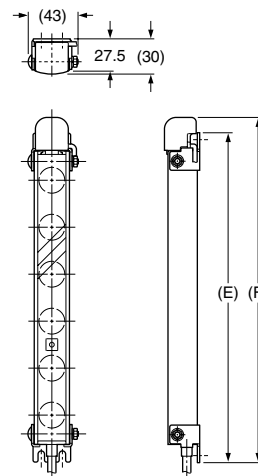
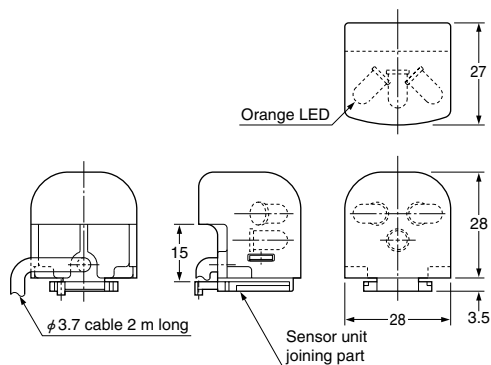

Model No.	E	F
NA40-4(-H)	210	223
NA40-6(-H)	280	293
NA40-8(-H)	360	373
NA40-10(-H)	440	453
NA40-12(-H)	520	533
NA40-14(-H)	600	613
NA40-16(-H)	680	693
NA40-20(-H)	840	853
NA40-24(-H)	1,000	1,013