

PM2 SERIES

Convergent Reflective Micro Photoelectric Sensor

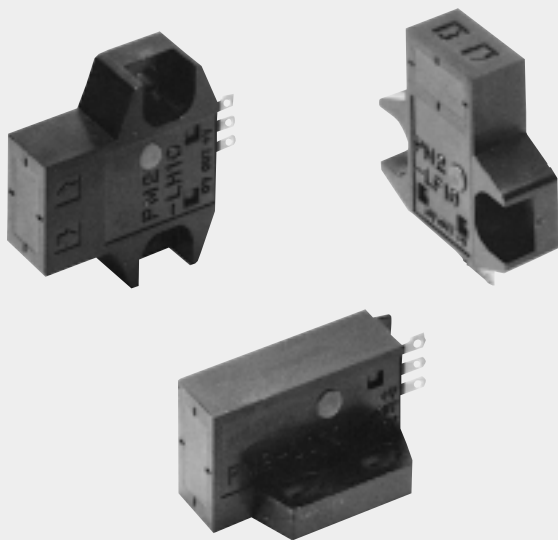

Convergent reflection sensing ensures stable detection



Conforming to EMC Directive

Stable detection by convergent reflective mode

Stable detection characteristics are obtained since it is convergent reflective type and senses a limited area.

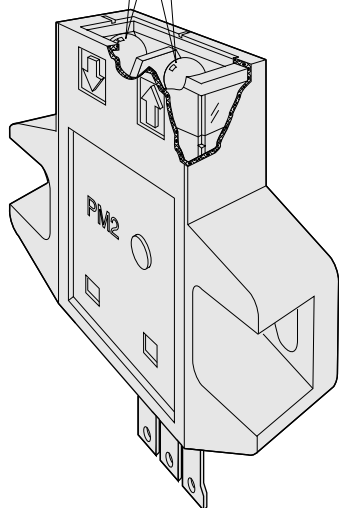
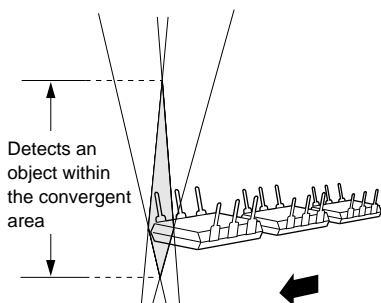

Not affected by background

Even a specular background does not affect the sensing performance if the sensor is located 30 mm 1.181 in away from it.

(However, the specular background should be a plane surface, directly facing the sensor. A spherical or curved background may be detected.)

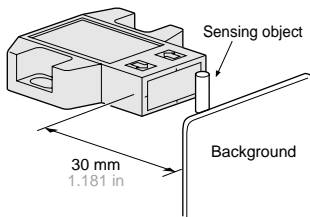

Dark object detectable

Since the sensor is very sensitive, it can detect even a dark object of low reflectivity.

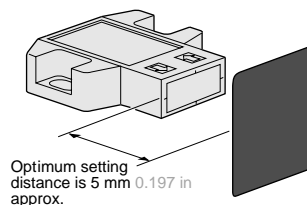

Minute object detectable

A $\phi 0.05$ mm $\phi 0.002$ in copper wire can be detected at a distance of 5 mm 0.197 in.

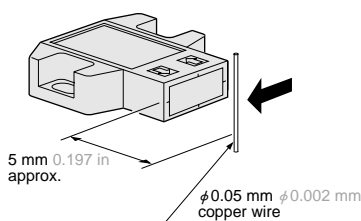

Cable type is also available

Cumbersome soldering is not required. It saves space and improves reliability.

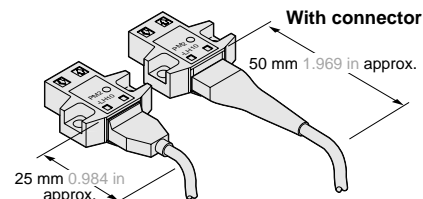

Cable type

APPLICATIONS

Sensing capacitors in a tray

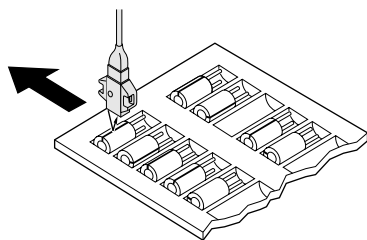

Sensing printed circuit boards

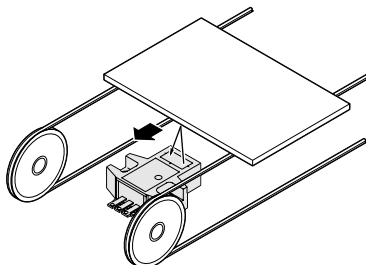

ORDER GUIDE

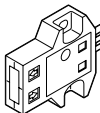
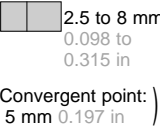
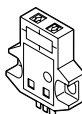
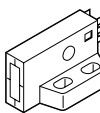
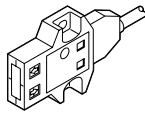
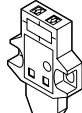
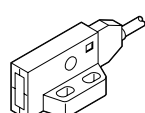
Type	Appearance	Sensing range	Model No.	Output	Output operation
Connector type			PM2-LH10	NPN open-collector transistor	Light-ON
			PM2-LH10B		Dark-ON
			PM2-LF10		Light-ON
			PM2-LF10B		Dark-ON
			PM2-LL10		Light-ON
			PM2-LL10B		Dark-ON
Cable type		PM2-LH10-C1	Light-ON		
		PM2-LH10B-C1	Dark-ON		
		PM2-LF10-C1	Light-ON		
		PM2-LF10B-C1	Dark-ON		
		PM2-LL10-C1	Light-ON		
		PM2-LL10B-C1	Dark-ON		

OPTIONS

Designation	Model No.	Description
Connector	CN-13	Dedicated connector
Mating cable	CN-13-C1	0.2 mm ² 3-core cabtyre cable, 1 m 3.281 ft long
	CN-13-C3	0.2 mm ² 3-core cabtyre cable, 3 m 9.843 ft long

Connector
• CN-13

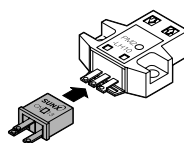

Mating cable
• CN-13-C1
• CN-13-C3

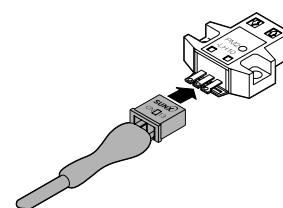

Amplifier Built-in	CY
	PX-2
Sensor Mounting Stand	RT-610
	MS-AJ
Micro	PM
	PM2
Multi-voltage	NX5
	VF
EQ-500	

I/O CIRCUIT AND WIRING DIAGRAMS

I/O circuit diagram

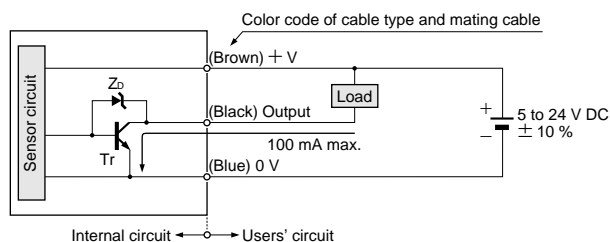

Wiring diagram

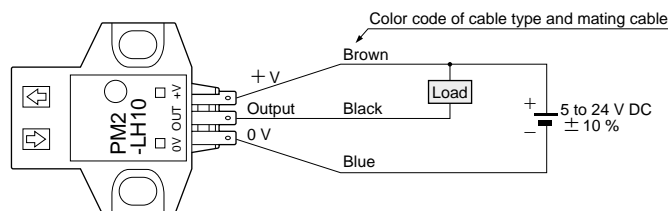

Note: Make sure to connect terminals correctly as the sensor does not incorporate a reverse polarity protection circuit.

Symbols ... Zb: Surge absorption zener diode
Tr: NPN output transistor

SENSING CHARACTERISTICS (TYPICAL)

Sensing fields

• Horizontal (left and right) direction

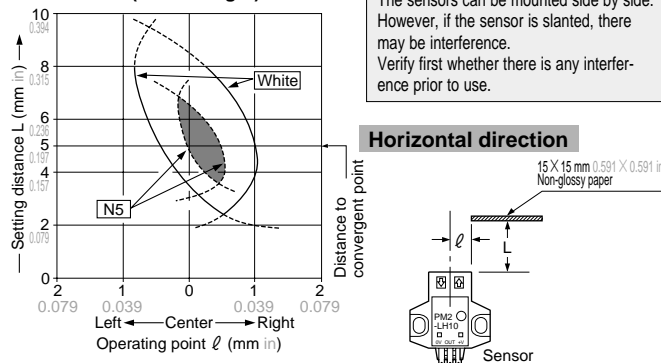

• Vertical (up and down) direction

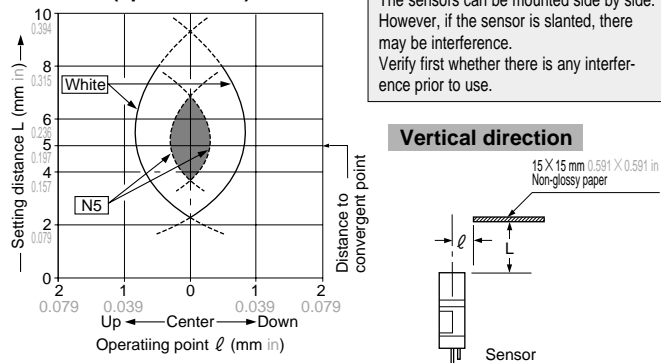

Correlation between lightness and sensing range

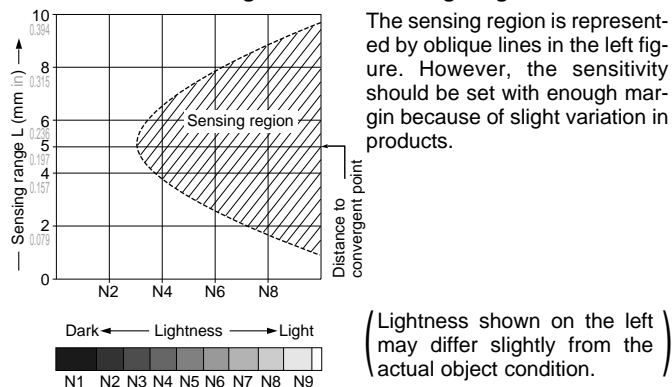

Correlation between material (15 X 15 mm 0.591 X 0.591 in) and sensing range

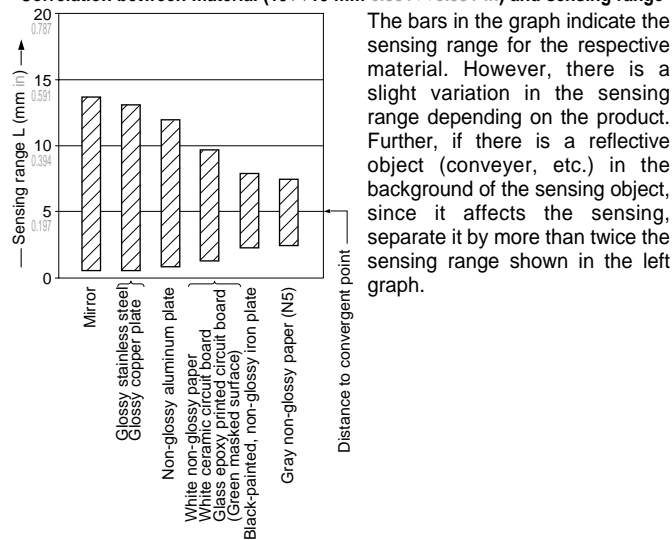

PRECAUTIONS FOR PROPER USE

Refer to p.1135~ for general precautions.

All models



This product is not a safety sensor. Its use is not intended or designed to protect life and prevent body injury or property damage from dangerous parts of machinery. It is a normal object detection sensor.

Mounting

- When fixing the sensor with screws, use M3 screws and the tightening torque should be 0.49 N·m or less. Further, use small, round type plain washers ($\phi 6$ mm $\phi 0.236$ in).

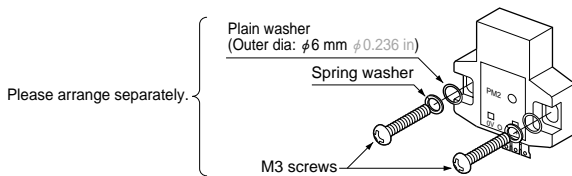

Wiring

- Make sure to connect terminals correctly as the sensor does not incorporate a reverse polarity protection circuit.
- If the sensor is being used in a noisy environment, examine the extent of noise. Further, if equipment, such as motor, solenoid or electromagnetic valve, which generates a large surge, is present near the sensor, connect a surge absorber to the equipment.

Setting

- The optimum setting distance (distance to convergent point) is 5 mm 0.197 in. The sensor is not affected even by a specular background if it is located 30 mm 1.181 in, or more, away from the sensor.

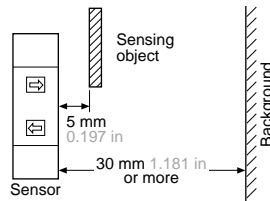

(However, the specular background should be a plane surface, directly facing the sensor. A spherical or curved background may be detected.)

Others

- Do not use during the initial transient time (50 ms) after the power supply is switched on.
- Take care that the product does not come in direct contact with oil, grease, or organic solvents, such as, thinner, etc.

Connector type

Cautions in plugging or unplugging a connector



- Do not plug or unplug a connector more than 10 times.
- Be sure not to give stress more than 5 N to a terminal of both a connector and a sensor. If you do not follow the above cautions, it will cause a poor contact.

Procedures of plugging or unplugging a connector

- Insert a connector straight into a sensor until the connector lug is locked by the sensor hook.

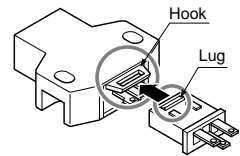

- When unplugging, give as much stress as a connector lug can be relieved from a hook. Then unplug it.

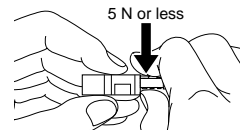

Caution: Be sure to hold a connector when plugging or unplugging it. Do not hold a terminal or a cable when plugging or unplugging the connector. Otherwise, it will cause a poor contact.

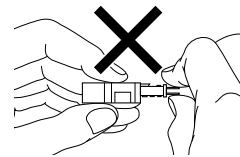

Soldering (Both connector CN-13 and sensor)

- If soldering is done directly on the terminals, strictly adhere to the conditions given below.

Soldering temperature	260 °C 500 °F or less
Soldering time	10 sec. or less
Soldering position	Refer to the below figure

Sensor

Connector

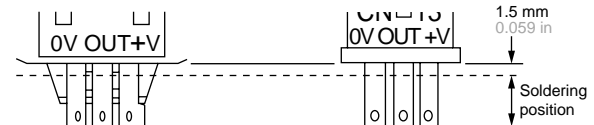

Wiring

- The cable length must be 2 m 6.562 ft, or less, with 0.3 mm², or more, cable. If the cable is extended for more than 2 m 6.562 ft, connect a capacitor of 10 μ F approx. between +V and 0 V terminals.

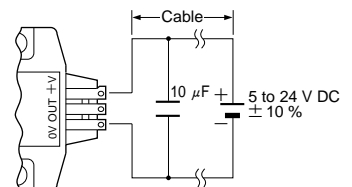

DIMENSIONS (Unit: mm in) The CAD data in the dimensions can be downloaded from the SUNX website: <http://www.sunx.co.jp/>

**PM2-LH10
PM2-LH10B** Sensor

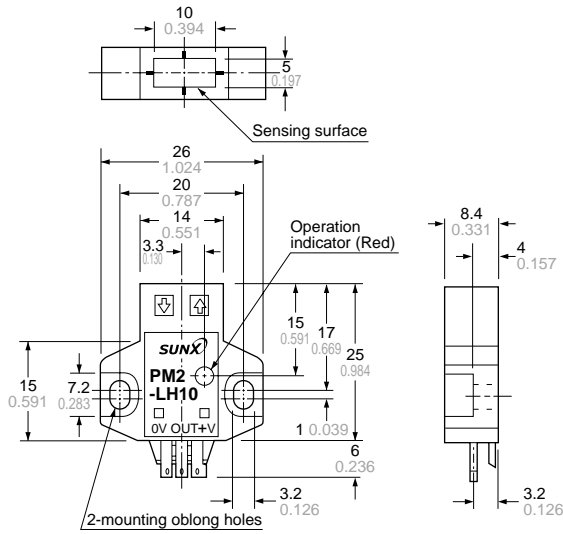

**PM2-LF10
PM2-LF10B** Sensor

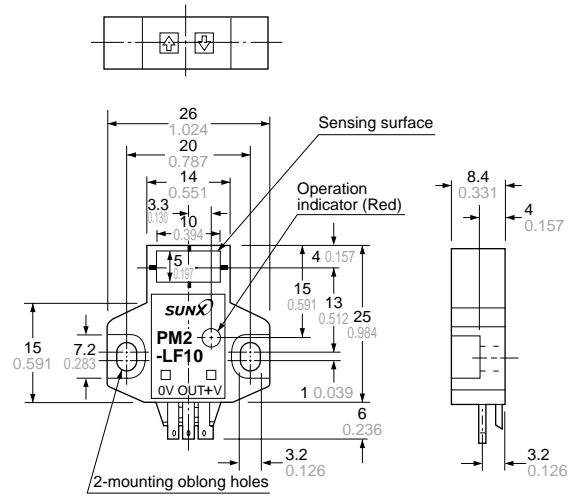

**PM2-LL10
PM2-LL10B** Sensor

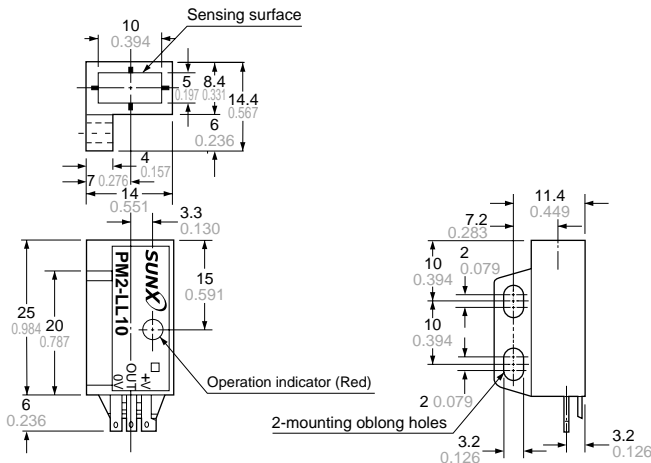

※ Terminal part (Connector type)

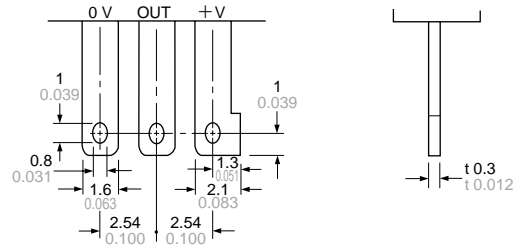

CN-13 Connector (Optional)

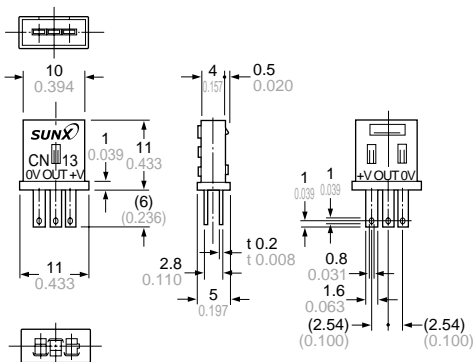

PM2

DIMENSIONS (Unit: mm in) The CAD data in the dimensions can be downloaded from the SUNX website: <http://www.sunx.co.jp/>

**PM2-LH10-C1
PM2-LH10B-C1** Sensor

**PM2-LF10-C1
PM2-LF10B-C1** Sensor

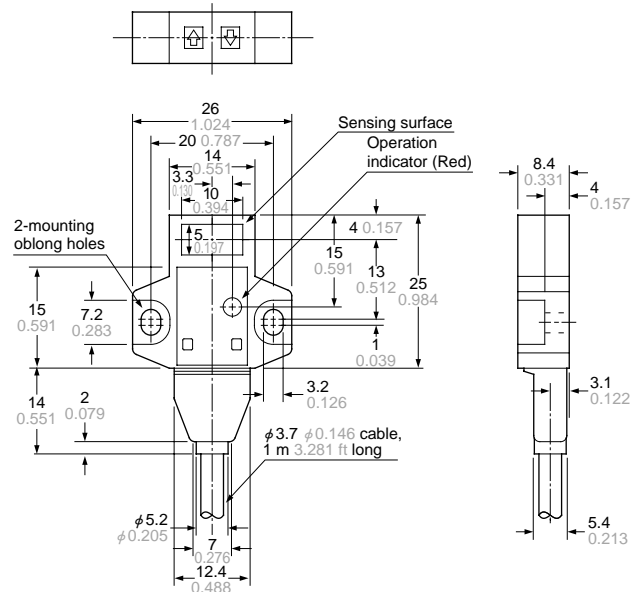
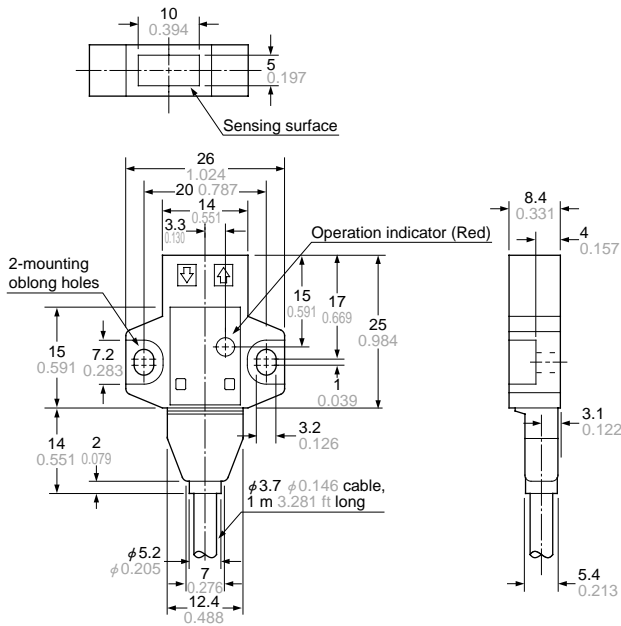

**PM2-LL10-C1
PM2-LL10B-C1** Sensor

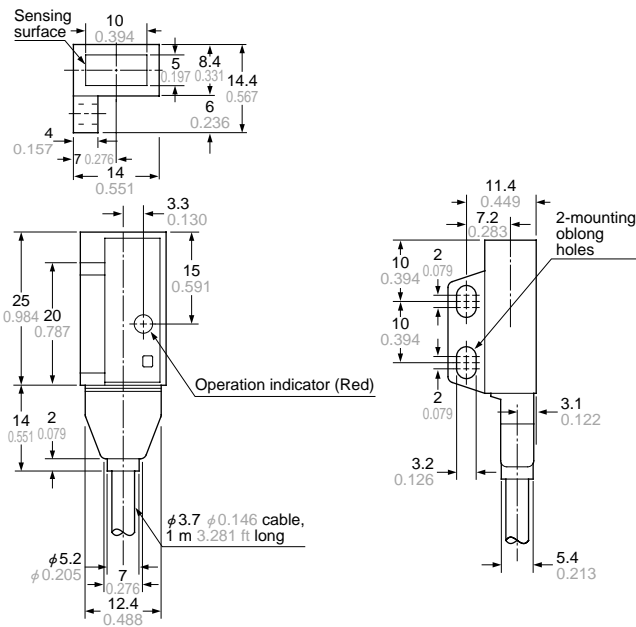

CY

PX-2

RT-610

MS-AJ

PM

PM2

NX5

VF

EQ-500

Amplifier Built-in

Sensor Mounting Stand

Micro

Multi-voltage